

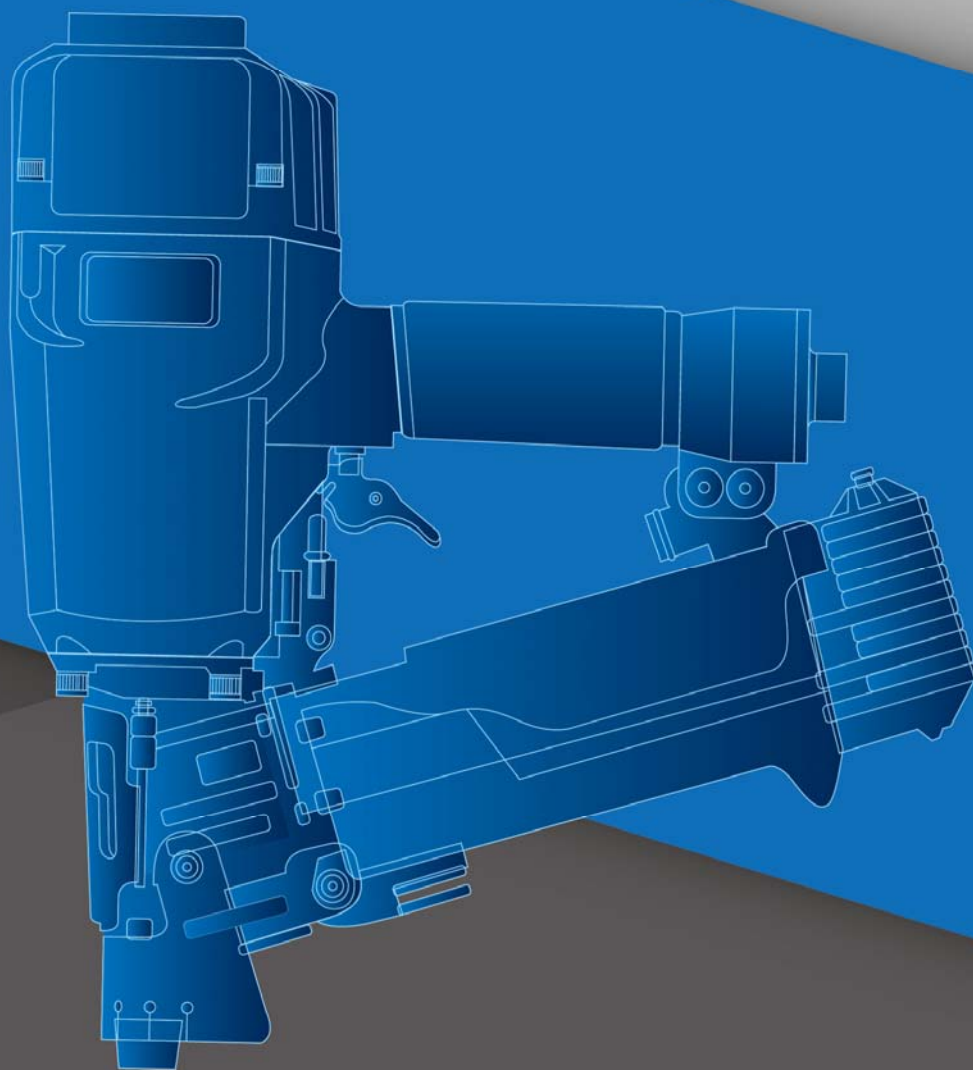

天工®

AIR NAILER
STAPLER
气动钉枪



2018 VERSION



工业工程
Industry Engineering



家具组合
Prefab Housing



装潢家具
Upholstered Furniture



细木工
Joiner



汽车业
Automotive Industry



包装业
Packaging



木工/屋顶
Carpenter Roofer



建筑组件
Building Components



鞋业
Shoe Making Industry



托盘业
Pallet Industry



厨/卧家具
Kitchen Bedroom Dining-room
Furniture



相框制作
Picture Frame



户外家具业
Outdoor Furniture Industry



重庆弘愿工具(集团)有限公司

地址: 重庆市巴南区李家沱花溪工业园 / 邮编: 400054 / 网址: www.hybest.com

特约经销商



弘愿公司保留更改产品与规格的权利, 如有变动请以说明书为准; 印刷可能使资料内产品与实物有差别; 所有资料经过仔细校对, 如有任何印刷错误, 本公司不承担因此产生之后果; 弘愿公司保留以上宣传数据的解释权; 表列有关数据仅供参考, 具体参数请以产品铭牌为准。



Authentication by CE
欧洲安全认证



ISO9001国际质量体系认证企业



重庆弘愿工具集团占地100亩，拥有60000余平方米的生产厂房。集团旗下拥有重庆弘愿工具有限公司、重庆弘愿压缩机制造有限公司、重庆弘愿动力设备制造有限公司、重庆弘愿金属表面技术有限公司，目前已具有年产150万支系列气动打钉枪、50万台小型空压机、10万台发电机组的生产能力。产品畅销全球30多个国家和地区。

企业注重技术开发，有27项研制成果获得了国家专利，55个产品通过了CE安全认证；20个产品通过CSA安全认证；14个产品通过EPA认证；5个产品通过CARB认证；6个产品通过欧洲排放认证。



Chongqing Hybest Tools Group is one of the largest air nailer/ stapler manufacturers in Mainland China, owns three subsidiary companies, which manufacturing air tool, air compressor, and power products.

With over 2 million pieces annual production capacity of all tools, 300,000 pieces of air compressors and 200,000 pieces of power products, which are widely sold in more than thirty countries and areas.

We pay special attention to the quality of our products and we have got 27 patents for our products, more than 55 products have got CE certificates, more than 20 products have CSA certificates, 14 products have got EPA certificates, 5 products have got CARB certificates and 6 products meet European emission standard.



2

热处理设备
Heat Treatment Equipment



4

力学测试
Mechanical Test



1

加工中心
Machining Center



3

三坐标仪
Three Coordinate Instrument



5

全自动生产线
Automatic Production Line



托盘专用枪 经典结构

HPCN55 / HPCN70 / HPCN83



包装专用枪 打钉深浅可调

HCN57P / HCN65P / HCN90P

The adjuster plate (see A) can be moved up and down. According to the length of nail, the adjuster plate should be adjusted correctly to the position indicated inside Lower nail housing.

MODEL HPCN83
Operating Air Pressure: 0.4-0.6 MPa
Length: 50-83mm
Stank Diameter: ϕ 5- ϕ 3.5mm
Load Capacity: 200-300PCS

HPCN55 托盘专用卷钉枪 Coil-Nailer Series



产品用途 Purpose



产品特性 Feature

重量	Weight: 2.7kg
尺寸	Size: 290*132*283
适用钉子线径	Shank Diameter: 2.1-2.3
使用气压	Air pressure: 6-8kg/cm ²
使用风管	Fitting tube: 8mm

HPCN70 托盘专用卷钉枪 Coil-Nailer Series



产品用途 Purpose



产品特性 Feature

重量	Weight: 3.7kg
尺寸	Size: 330*134*308
适用钉子线径	Shank Diameter: 2.3-2.9
使用气压	Air pressure: 6-8kg/cm ²
使用风管	Fitting tube: 8mm

HPCN83 托盘专用卷钉枪 Coil-Nailer Series



产品用途 Purpose



产品特性 Feature

重量	Weight: 3.9kg
尺寸	Size: 330*132*340
适用钉子线径	Shank Diameter: 2.5-3.33
使用气压	Air pressure: 6-8kg/cm ²
使用风管	Fitting tube: 8mm

F30 直钉枪 Brad Nailer



产品用途 Purpose



产品特性 Feature

使用气压 Air pressure : 4~7kg/cm²
 弹夹容量 Capacity: 100枚
 使用接管 Fitting tube: 6mm

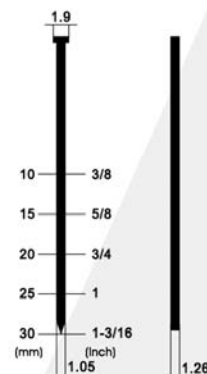

F30K 开式弹夹直钉枪 Brad Nailer



产品用途 Purpose



产品特性 Feature

使用气压 Air pressure : 4~7kg/cm²
 弹夹容量 Capacity: 100枚
 使用接管 Fitting tube: 6mm

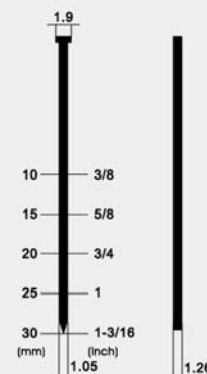

F30 快换 直钉枪 Brad Nailer



产品用途 Purpose



产品特性 Feature

使用气压 Air pressure : 4~7kg/cm²
 弹夹容量 Capacity: 100枚
 使用接管 Fitting tube: 6mm

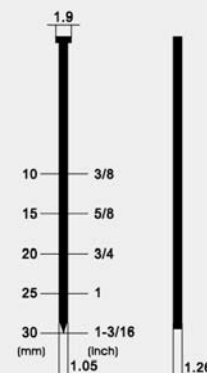

T50 直钉枪 Brad Nailer



产品用途 Purpose



产品特性 Feature

使用气压 Air pressure : 5~8kg/cm²
 弹夹容量 Capacity: 100枚
 使用接管 Fitting tube: 6mm

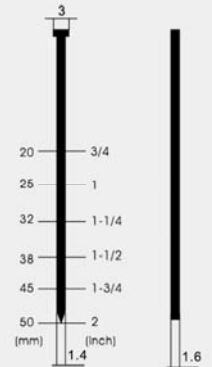

ST38 钢钉枪 Concrete T Nailer



产品用途 Purpose



产品特性 Feature

使用气压 Air pressure : 5~8kg/cm²
 弹夹容量 Capacity: 50枚
 使用接管 Fitting tube: 8mm

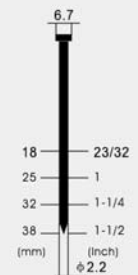

ST64 钢钉枪 Concrete Nailer



产品用途 Purpose



产品特性 Feature

使用气压 Air pressure : 5~8kg/cm²
 弹夹容量 Capacity: 50枚
 使用接管 Fitting tube: 8mm

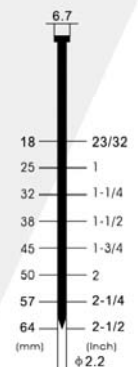

425K 码钉枪 Fine Wire Stapler



产品用途 Purpose



产品特性 Feature

使用气压 Air pressure : 4~7kg/cm²
 弹夹容量 Capacity: 100枚
 使用接管 Fitting tube: 6mm

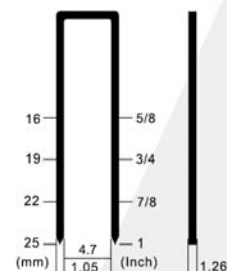

422J 码钉枪 Fine Wire Stapler



产品用途 Purpose



产品特性 Feature

使用气压 Air pressure : 4~7kg/cm²
 弹夹容量 Capacity : 100枚
 使用接管 Fitting tube : 6mm

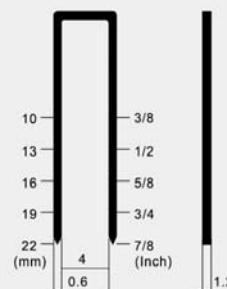

1022J 码钉枪 Fine Wire Stapler



产品用途 Purpose



产品特性 Feature

使用气压 Air pressure : 4~7kg/cm²
 弹夹容量 Capacity : 100枚
 使用接管 Fitting tube : 6mm

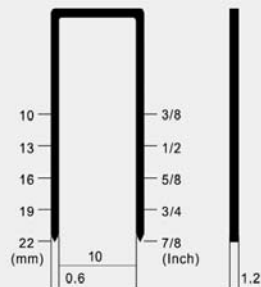

1013J/1010F 码钉枪 Fine Wire Stapler



产品用途 Purpose



产品特性 Feature

使用气压 Air pressure : 4~7kg/cm²
 弹夹容量 Capacity: 100枚
 使用接管 Fitting tube: 6mm

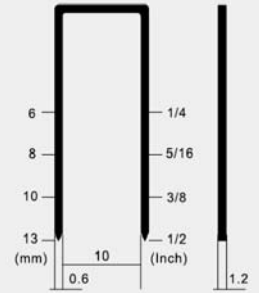

F钉线径: 0.7mmX0.5mm

1013JL/1010FL 码钉枪 Fine Wire Stapler



产品用途 Purpose



产品特性 Feature

使用气压 Air pressure : 4~7kg/cm²
 弹夹容量 Capacity: 100枚
 使用接管 Fitting tube: 6mm

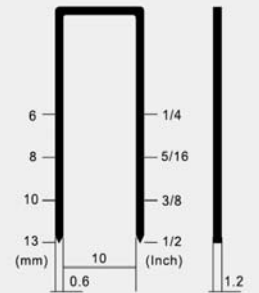

F钉线径: 0.7mmX0.5mm

1006J/1006F 小码钉枪 Fine Wire Stapler



产品用途 Purpose



产品特性 Feature

使用气压 Air pressure : 4~7kg/cm²
 弹夹容量 Capacity : 100枚
 使用接管 Fitting tube : 6mm

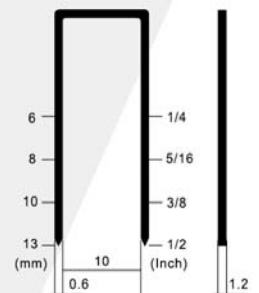

F钉线径: 0.7mmX0.5mm

440K 码钉枪 Medium Wire Stapler



产品用途 Purpose



产品特性 Feature

使用气压 Air pressure : 5~8kg/cm²
 弹夹容量 Capacity: 100枚
 使用接管 Fitting tube: 6mm

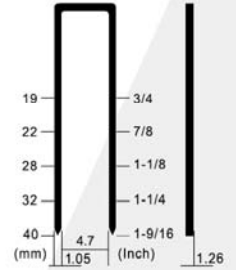

9240 码钉枪 Medium Wire Stapler



产品用途 Purpose



产品特性 Feature

使用气压 Air pressure : 5~8kg/cm²
 弹夹容量 Capacity: 100枚
 使用接管 Fitting tube: 6mm

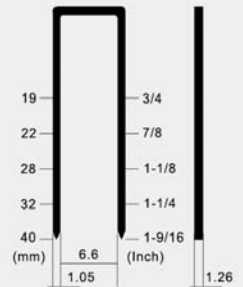

N838 / N838T 码钉枪 Medium Wire Stapler



产品用途 Purpose



产品特性 Feature

使用气压 Air pressure : 5~8kg/cm²
 弹夹容量 Capacity: 80枚
 使用接管 Fitting tube: 6mm

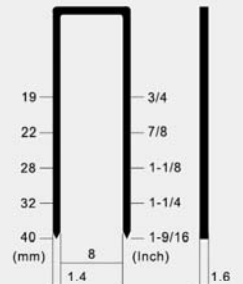

• **N838T**
 特制钉头，带磁铁
 专用于沙发木架弹簧扣的安装

N851 码钉枪 Large Stapler



产品用途 Purpose



产品特性 Feature

使用气压 Air pressure: 5~8kg/cm²
 弹夹容量 Capacity: 80枚
 使用接管 Fitting tube: 8mm

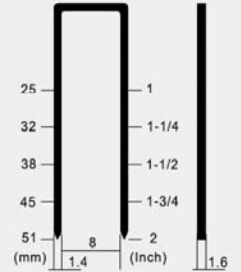

ATP50 拔钉枪 Air Nailer Puller



产品用途 Purpose

适用于普通圆铁钉的拆除与紧钉

产品特性 Feature

使用气压 Air pressure: 5~8kg/cm²
 使用接管 Fitting tube: 6mm

DK50/DK64 打孔枪 Perforating Gun



产品用途 Purpose

适用于2毫米以下的薄铁皮打孔

产品特性 Feature

使用气压 Air pressure: 5~8kg/cm²
 使用接管 Fitting tube: 6mm

TD1170 图钉枪 Thumbtack Air Nailer



产品用途 Purpose

打各种装饰钉，适用软包装饰
欧式沙发装饰钉
(钉帽直径 10.8mm~11.7mm)

产品特性 Feature

使用气压 Air pressure: 4~7kg/cm²
弹夹容量 Capacity: 1枚
使用接管 Fitting tube: 6mm



胶粒枪 Rubber Nailer



产品用途 Purpose

用于快速安装板式家具预埋件
(胶质螺母)

产品特性 Feature

使用气压 Air pressure: 4~7kg/cm²
弹夹容量 Capacity: 20枚
使用接管 Fitting tube: 6mm



1314/1310S 树脂枪 Jaffaite Nailer



产品用途 Purpose

使用树脂材料码钉，用于生态板芯材生产
高级家具生产、汽车轮胎修补等

产品特性 Feature

使用气压 Air pressure: 4~7kg/cm²
弹夹容量 Capacity: 80枚
使用接管 Fitting tube: 6mm

B120 气动保温枪 Pneumatic Heat Preservation Nailer



可更换加长枪管，适用于200mm保温钉

产品用途 Purpose

适用于各种软态保温板的快速安装

产品特性 Feature

重量	Weight: 3.2kg
长x宽x高	Size: 420x400x170
钉子长度	Nail Length: 25~200mm
使用气压	Air Pressure: 6~8kg/cm
使用风管	Fitting Tube: 8mm



B120C 小保温枪 Small Heat Preservation Nailer



产品用途 Purpose

适用于各种软态保温板的快速安装

产品特性 Feature

重量	Weight: 3.3kg
长x宽x高	Size: 300x340x100
钉子长度	Nail Length: 25~100mm
使用气压	Air Pressure: 6~8kg/cm
使用风管	Fitting Tube: 8mm



瓦斯保温枪 Gas Nailer Series



可更换加长枪管，适用于200mm保温钉

产品用途 Purpose

适用于各种软态保温板的快速安装

产品特性 Feature

重量	Weight: 3.0kg
长x宽x高	Size: 400x123x476
钉子长度	Nail Length: 25~200mm
工作电压	Voltage: 7.2V
耗气量	Gas Consumption: 1000~1200次/罐
打钉频率	Frequency: 120次/分钟
装钉容量	Capacity: 1



GSR40A 弘愿 Gas Nailer Series



产品用途 Purpose

使用瓦斯钢钉，打铝合金门窗的连接片，快速固定门窗
适用于门窗安装，水暖管道固定等各种紧固性连接

产品特性 Feature

重量	Weight: 3.5kg
长x宽x高	Size: 453x110x387
钉子型号	ShankDiameter: Φ 2.6~ Φ 3塑排钢钉
钉子长度	NailLength: 15~40mm
工作电压	Voltage: 7.2V
耗气量	Gas Consumption: 1000~1200次/罐
打钉频率	Frequency: 120次/分钟
装钉容量	Capacity: 30



GSR40A 天工 Gas Nailer Series



产品用途 Purpose

使用瓦斯钢钉，打铝合金门窗的连接片，快速固定门窗
适用于门窗安装，水暖管道固定等各种紧固性连接

产品特性 Feature

重量	Weight: 3.5kg
长x宽x高	Size: 453x110x387
钉子型号	ShankDiameter: Φ 2.6~ Φ 3塑排钢钉
钉子长度	NailLength: 15~40mm
工作电压	Voltage: 7.2V
耗气量	Gas Consumption: 1000~1200次/罐
打钉频率	Frequency: 120次/分钟
装钉容量	Capacity: 30



GSR40A ZS Gas Nailer Series



产品用途 Purpose

使用瓦斯钢钉，打铝合金门窗的连接片，快速固定门窗
适用于门窗安装，水暖管道固定等各种紧固性连接

产品特性 Feature

重量	Weight: 3.5kg
长x宽x高	Size: 453x110x387
钉子型号	ShankDiameter: Φ 2.6~ Φ 3塑排钢钉
钉子长度	NailLength: 15~40mm
工作电压	Voltage: 7.2V
耗气量	Gas Consumption: 1000~1200次/罐
打钉频率	Frequency: 120次/分钟
装钉容量	Capacity: 30



GSR40A Gas Nailer Series



产品用途 Purpose

使用瓦斯钢钉，打铝合金门窗的连接片，快速固定门窗
适用于门窗安装，水暖管道固定等各种紧固性连接

产品特性 Feature

重量	Weight: 3.5kg
长x宽x高	Size: 453x110x387
钉子型号	Shank Diameter: Φ 2.6- Φ 3塑排钢钉
钉子长度	Nail Length: 15~40mm
工作电压	Voltage: 7.2V
耗气量	Gas Consumption: 1000~1200次/罐
打钉频率	Frequency: 120次/分钟
装钉容量	Capacity: 30



GSR40 高原枪 Gas Nailer Series



产品用途 Purpose

使用瓦斯钢钉，打铝合金门窗的连接片，快速固定门窗
适用于门窗安装，水暖管道固定等各种紧固性连接

产品特性 Feature

重量	Weight: 3.5kg
长x宽x高	Size: 400x123x476
钉子型号	Shank Diameter: Φ 2.6- Φ 3塑排钢钉
钉子长度	Nail Length: 15~40mm
工作电压	Voltage: 7.2V
耗气量	Gas Consumption: 1000~1200次/罐
打钉频率	Frequency: 120次/分钟



SR40/SR65 气动钢钉枪 Pneumatic Steel Nail Nailer



产品用途 Purpose

使用瓦斯钢钉，打铝合金门窗的连接片，快速固定门窗
适用于门窗安装，水暖管道固定等各种紧固性连接

产品特性 Feature

重量	Weight: 3.4kg
长x宽x高	Size: 380x400x130
钉子型号	Shank Diameter: Φ 2.6- Φ 3塑排钢钉
钉子长度	Nail Length: 15~40mm
打钉频率	Frequency: 120次/分钟
装钉容量	Capacity: 30
使用气压	Air pressure: 6~8kg/cm ²

无瓦斯罐
使用普通空压机作动力

